

CS-3 SERIES

E-RATED/MEDIUM VOLTAGE FUSES

8.25kV Ferrule Mounted

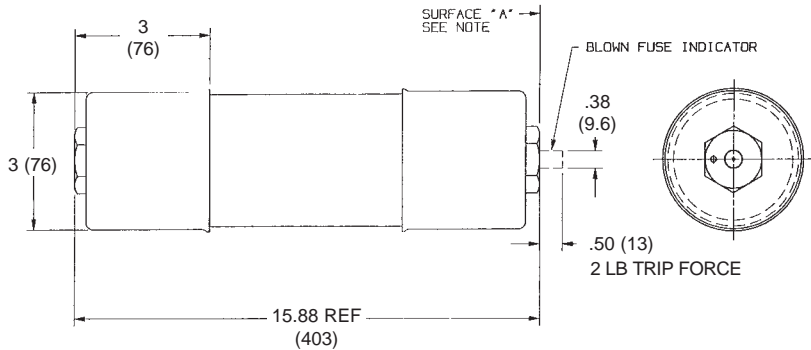

Figure A

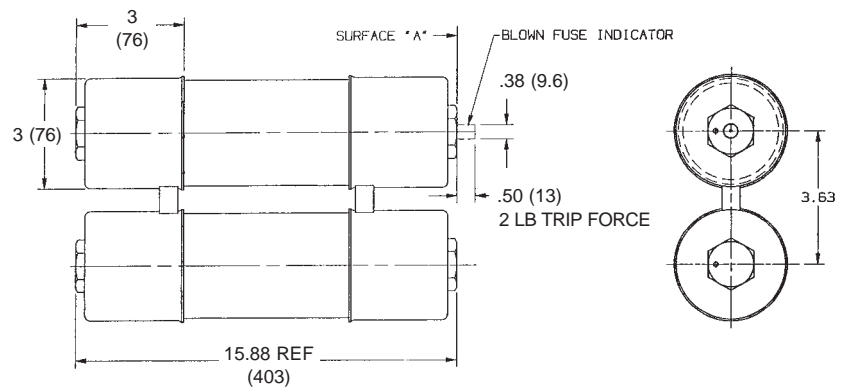

Figure B



CATALOG NUMBER	AMPERE RATING	NUMBER OF BARRELS	FIG.	INTERRUPTING RATING RMS SYM. AMPERES*
8.25kV MAX. FERRULE MOUNTED STYLE - 12" (305 mm) CLIP CENTER - 3" (76.2 mm) BARREL DIAMETER				
A825X10E-1	10E	1	A	50,000
A825X15E-1	15E	1	A	
A825X20E-1	20E	1	A	
A825X25E-1	25E	1	A	
A825X30E-1	30E	1	A	
A825X40E-1	40E	1	A	
A825X50E-1	50E	1	A	
A825X65E-1	65E	1	A	
A825X80E-1	80E	1	A	
A825X100E-1	100E	1	A	
A825X125E-1	125E	2	B	50,000
A825X150E-1	150E	2	B	
A825X200E-1	200E	2	B	

* RMS ASYM. AMPS = RMS SYM. AMPERES x 1.6

CS-3 SERIES

E-RATED/MEDIUM VOLTAGE FUSES

A825X (10E to 200E) -1

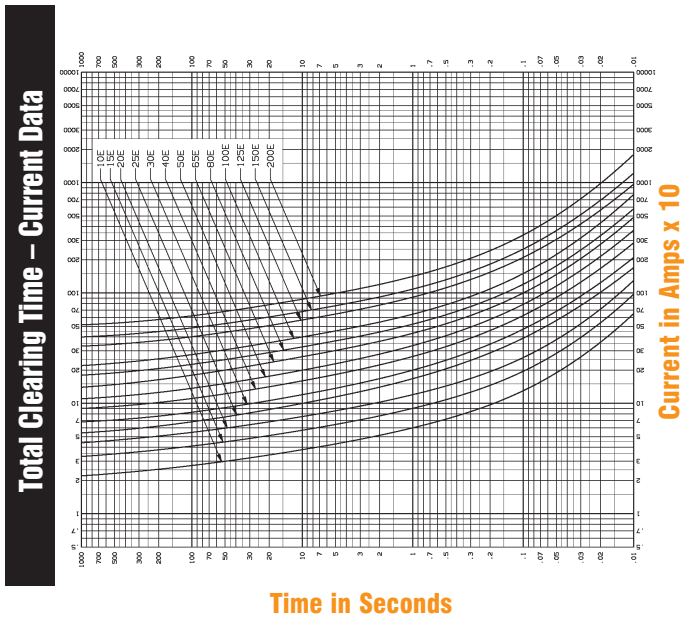

A825X (10E to 200E) -1

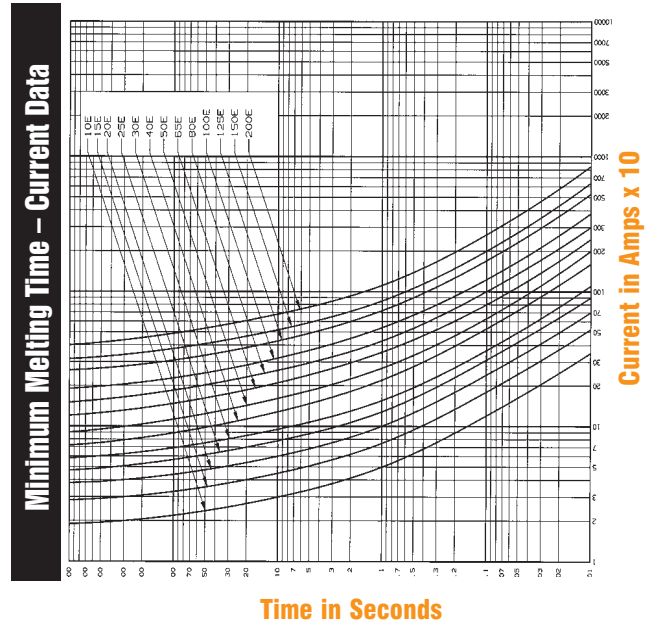

A825X (10E to 200E) -1

Peak Let-Thru Current Data, E-Rated Fuses

