

# AFH, AF2H, AF3H

## AUTOMOTIVE FUSE HOLDERS



In-line fuseholders for blade type automobile fuses. 4" stranded wire leads are stripped back 1/4".

Catalog Number	Fuse Type & Max Amp.	Volts	Body Color	AWG/Color
AFH20-14	AF Fuse/ 20A	32V	Black	#14/Black
AFH20-14Y	AF Fuse/ 20A	32V	Yellow	#14/Black
AFH20-16	AF Fuse/ 20A	32V	Yellow	#16/Black
AFH20-16Y	AF Fuse/ 20A	32V	Yellow	#16/Black

**C**

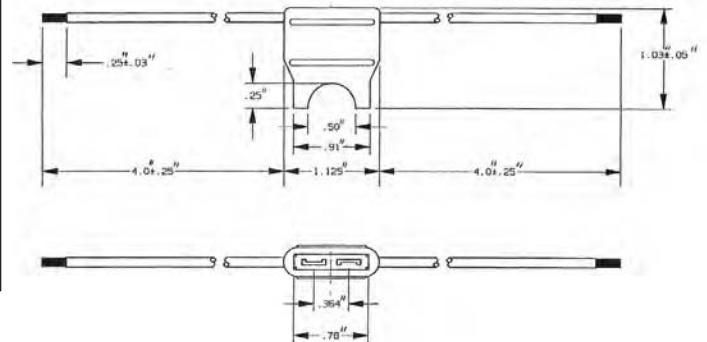

Catalog Number	Fuse Type & Max Amp.	Volts	Body Color	AWG/Color
AFH30-12	AF Fuse/ 30A	32V	Black	#12/Yellow
AFH30C	AF Fuse/ 30A	32V	Black	#12/Orange

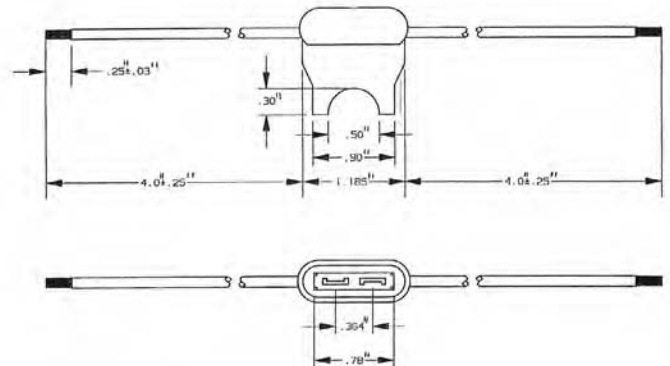

# AFH, AF2H, AF3H

# AUTOMOTIVE FUSE HOLDERS



Catalog Number	Fuse Type & Max Amp.	Volts	Body Color	AWG/Color
AF2H30C	AF Fuse/ 30A	32V	Black	#12/Orange

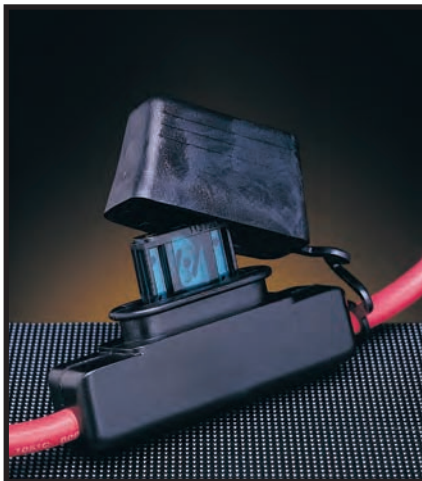
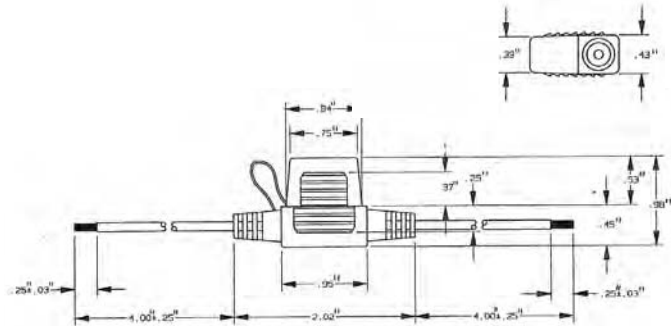

Catalog Number	Fuse Type & Max Amp.	Volts	Body Color	AWG/Color
AF3H60C	AF Fuse/ 60A	32V	Black	#6/Red

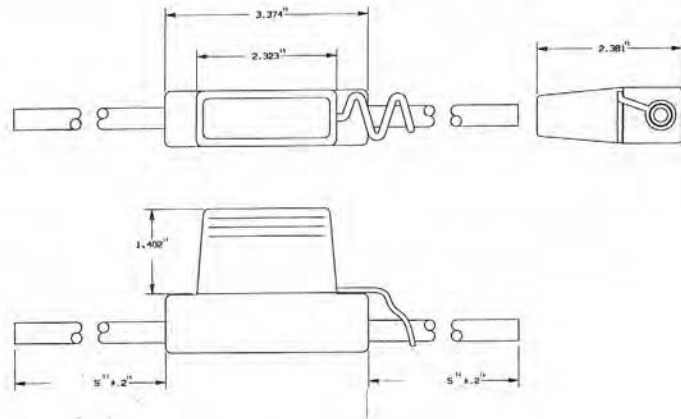

**Peak Let-Through Current Data**

**Melting Time – Current Data**

Maximum Instantaneous Peak Let-Through Amperes

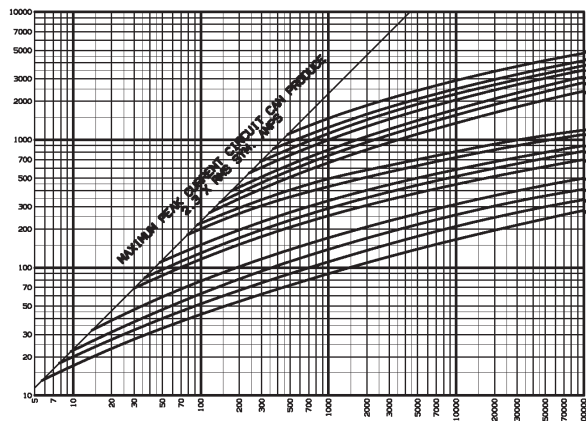

Available Current in RMA Symmetrical Amperes

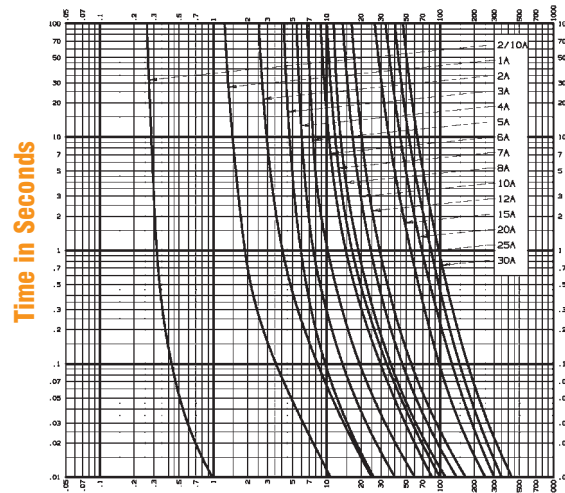

Current in Amperes