

2000V DC

SQUARE-BODY/SPECIAL PURPOSE

2000 V DC SRD from 160 to 400 A Size 122



➤ **Dimensions**

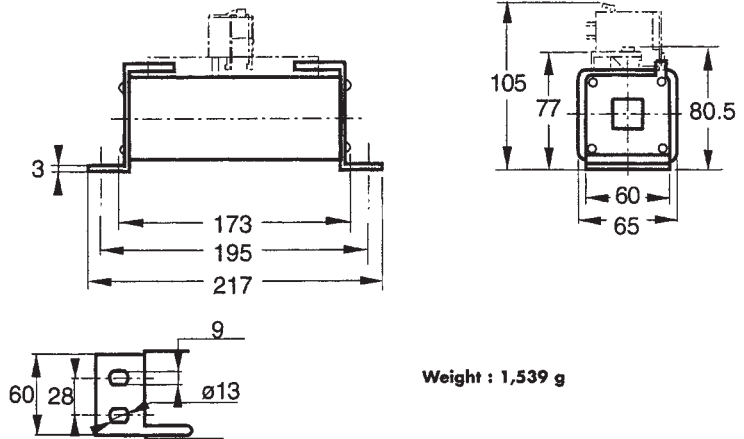

Weight : 1,539 g

MAIN CHARACTERISTICS

SIZE	CURRENT RATING I_n (A)	INTERRUPTING RATING	MAXIMUM I_2t @1600V=		WATTS LOSS		CATALOG NUMBER (1)	REF. NUMBER
			L/R = 15ms	L/R = 45ms	0.8 I_n	I_n		
122	160	@ 1800V DC	15000	25000	52.5	100	CC 20 SRD 122 QF 0160	D 076639
	200	100kA	26000	44000	61.5	118	CC 20 SRD 122 QF 0200	X 079462
	250	L/R = 30ms	50000	87000	69	131	CC 20 SRD 122 QF 0250	Y 079463
	315	@ 2000V DC	117000	200000	74	150	CC 20 SRD 122 QF 0315	Z 079464
	400	100kA L/R = 15ms	219000	380000	87	175	CC 20 SRD 122 QF 0400	A 079465

Microswitch: MCR 3E 1-5N BS Ref. Number: D310023

2000V DC

SQUARE-BODY/SPECIAL PURPOSE

ELECTRICAL CHARACTERISTICS

DC Voltage Capabilities vs. Time Constant

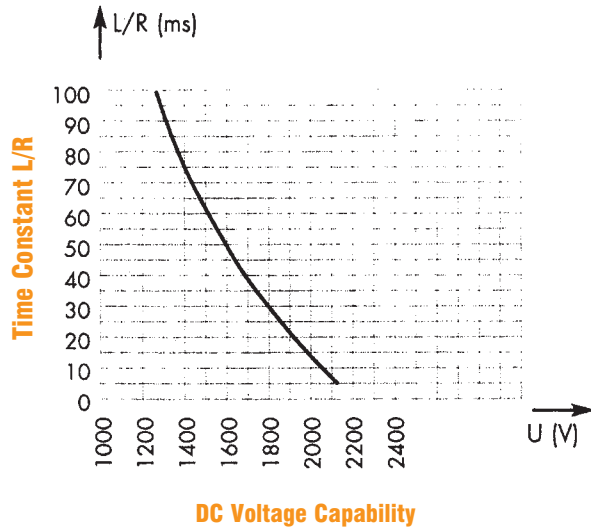

Above: Curve indicates maximum permissible value of time constant L/R as a function of DC working voltage

Peak Arc Voltage vs. Working Voltage

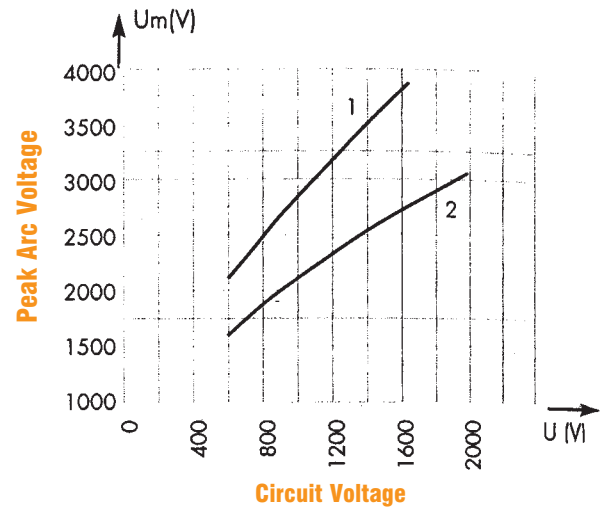

1 : L/R = 45 ms
2 : L/R = 15 ms

Melting Time vs. Current Data

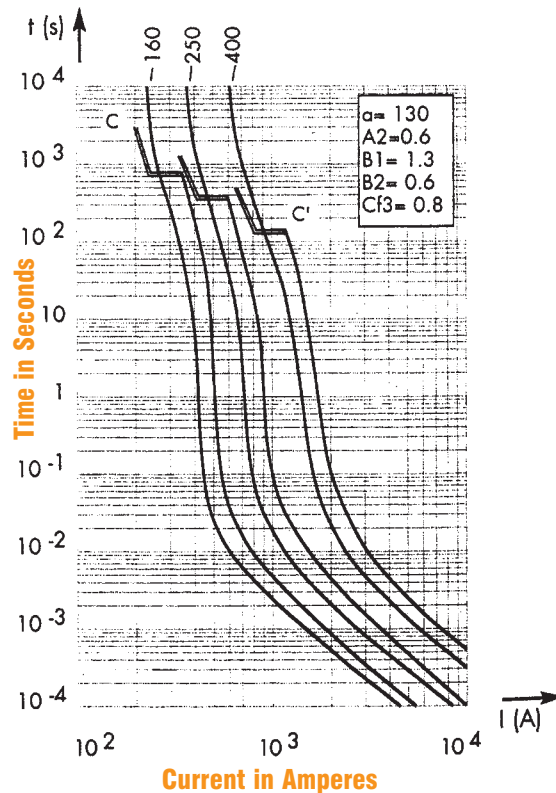
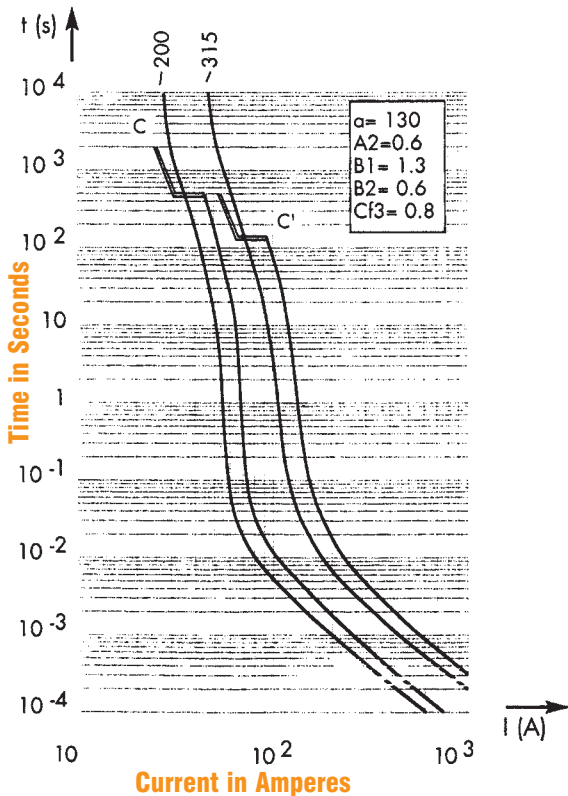

Above: Curves indicate, for each rated current, pre-arcing (melting) time vs. R.M.S. pre-arcing (melting) current.

G