

660-750V DC

SQUARE-BODY/SPECIAL PURPOSE



750 V DC
gRC - gRB - grD from 1000 to 1600 A
Size 2x123

➤ **Dimensions**

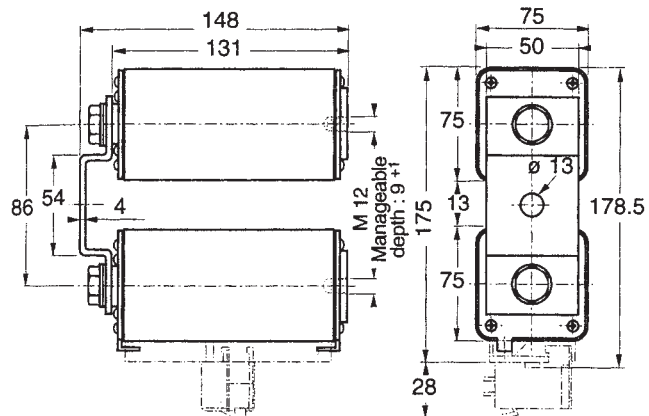

Weight: 3,600 g

MAIN CHARACTERISTICS

SIZE	CURRENT RATING I_N (A)	INTERRUPTING RATING	MAXIMUM I^2t @900V=L/R 40ms		WATTS LOSS		CATALOG NUMBER	REF. NUMBER
			$I_p=10I_N$	$I_p=50I_N$	$0.8 I_N$	I_N		
2 x 123	1000	@ 750V DC 100kA L/R = 100ms	20 10^6	4 10^6	102	187	CC 7,5 gRC 2123 TTF 1000	Z 090481
		@ 900V DC 100kA L/R = 40ms						
			Maximum I^2t (A ² s) @800V DC L/R 40ms					
			$I_p=10I_N$	$I_p=50I_N$				
	1250 1400 1500	@ 750V DC 100kA L/R = 50ms	30 10^6 40 10^6 40 10^6	6 10^6 8 10^6 8 10^6	148 164 164		CC 7,5 gRB 2123 TTF 1250 CC 7,5 gRB 2123 TTF 1400 CC 7,5 gRD 2123 TTF 1500	D 098558 B 090483 K 220947
			Maximum I^2t (A ² s) @660V = L/R 30ms					
		$I_p=10I_N$	$I_p=50I_N$					
1600 (660 V)	@ 660V DC 100kA L/R = 50ms	48.6 10^6	10 10^6	180		CC 6.6 gRB 2123 TTF 1600	L 220948	

Microswitch: MC 3E 1-5N Ref. Number: D310020

660-750V DC

SQUARE-BODY/SPECIAL PURPOSE

ELECTRICAL CHARACTERISTICS

DC Voltage Capabilities vs. Time Constant

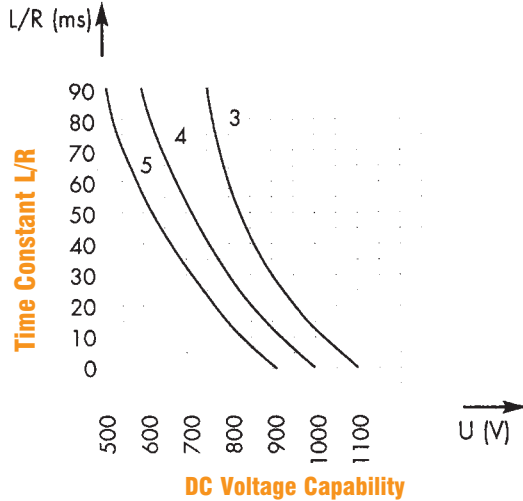

- 3: curve gRC
- 4: curve gRB
- 5: curve gRD

Above: Curves indicate maximum permissible value of time constant L/R as a function of DC working voltage.

Peak Arc Voltage vs. Working Voltage

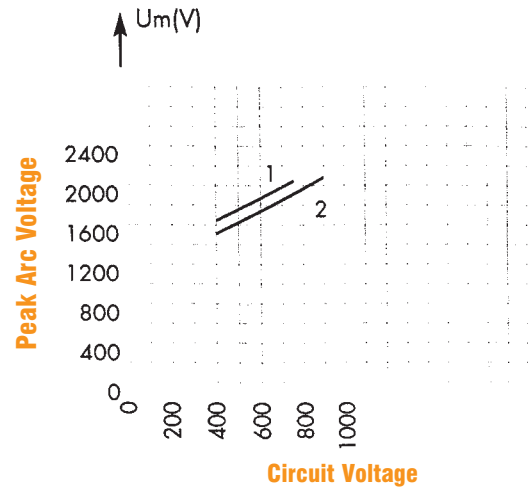

- 1: L/R = 100 ms
- 2: L/R = 40 ms

Melting Time vs. Current Data

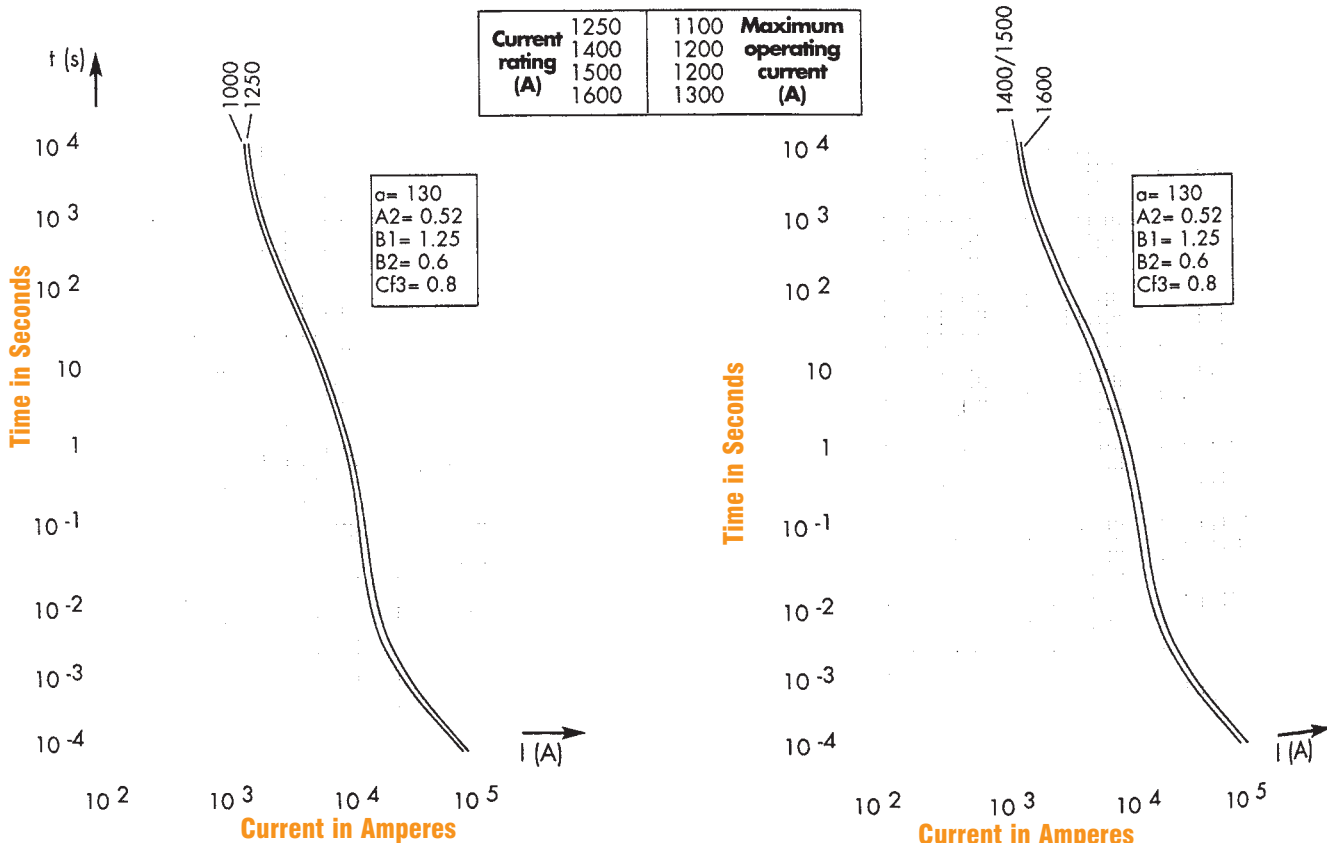

Above, left and right: curves indicate, for each rated current, pre-arcing (melting) time vs. R.M.S. pre-arcing (melting) current.

± 7% tolerance for mean pre-arcing (melting) current