

PROTISTOR FUSE MICROSWITCHES ACCESSORIES



PROTISTOR® FUSES

MICROSWITCH SYSTEMS FOR ROUND AND SQUARE-BODY FUSES (not for PSC Fuses)

Features/Benefits

- Remote signaling systems for fitting on Ferraz Shawmut fuses equipped with microswitch support
- Indication of fuse status
- Manual Reset
- Standard and low current models with different insulation ratings
- Watertight types for use in corrosive atmospheres

CHARACTERISTICS

TYPE	CATALOG NUMBER	AC or DC Insulation voltage rating Ui (V)	AC voltage withstand test (.)	Impulse voltage test Uimp 1,2/50 hs (.)	Positive operating min.voltage /min.current	Current rating							
							Current	Non-inductive circuit			inductive circuit L/R = 25ms		
								30 V	110 V	250 V	30 V	110 V	250 V
Standard	MC3E 1-5N	1250V	15 kV	20 kV	20 V	5 A	50/60 Hz	10 A	10 A	7 A			6 A
	MCR3E 1-5N	2200V	20 kV	30 kV	50 mA		DC	5 A	0.5 A		1.6 A	0.3A	
Low level	MC3E 1-5NBS	1250V	15 kV	20 kV	10 V 10 mA	3 A	50/60 Hz	3 A	3 A	3 A	2 A	1 A	1 A
	MC3E 1-9NBS												
	MCR3E 1-5NBS	2200V	20 kV (1)	30 kV			DC	3 A	0.5 A	0.25 A	3 A	0.2 A	0.1 A
	MCR3E 1-9NBS		23 kV (2)										
	MC2R3E 1-5BS	6000V	24 kV (1)	40 kV			3 A	0.5 A	0.25 A	3 A	0.2 A	0.1 A	
MC2R3E 1-9NBS	26 kV (2) 32 kV (3)												
Watertight IP 50	MC3E 1-5NET	1250V	11 kV	16 kV	10 V 10 mA	3 A	50 Hz		3 A	3 A		1 A	1 A
	MCR3E 1-5NET	2200V	20 kV (1)	30 kV			DC		0.5A			0.2 A	
	MC2R3E 1-5NET	6000V	24 kV (2)	40 kV									

Catalog Numbering system: MC3E 1-5 single pole microswitch - MC3E 1-9 double pole microswitch - MCR, MC2R reinforced insulation microswitch

* Between power circuit and microswitch terminals as per IEC 60 and 694 and NFC 64010 (50/60 Hz 1 min. duration in dry air)

** Between power circuit and microswitch terminals Uimp: impulse voltage according to IEC 947-1

***Between power circuit and microswitch terminals

EACH MICROSWITCH WEIGHS LESS THAN 100g, THEREFORE NO FUME AND SMOKE GRADE IS REQUIRED BY NF F16-102 STANDARD

(1) for short body fuses (sizes 30 - 31 - 32 - 33 - 70 - 71 - 72 - 73 - 83 - 84) Except PSC

(2) for sizes 100 - 91 - 92 - 93 - 94 - 123 - 124 fuses and longer

(3) for sizes 171 - 172 - 173 - 174 fuses and longer

PROTISTOR FUSE MICROSWITCHES ACCESSORIES

Remote Signalling with 1250 V AC/DC Insulation Voltage

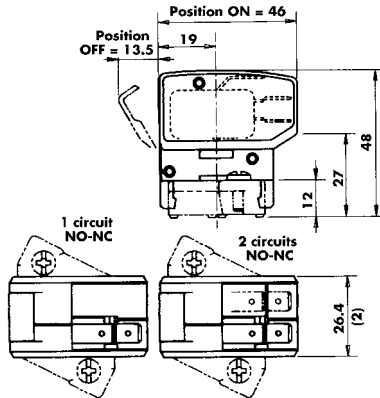

Quantity of NO-NC separated circuits	Contact	Catalog Number	Ref. Number	Weight (g)	Pack. (1)
1	standard	MC3E 1-5N	D310020	39.5	3
1	low level	MC3E 1-5NBS	E310021	39.5	3
2	low level	MC3E 1-9NBS	F310022	45.7	3
1	watertight	MC3E 1-5NET	L310027	40.2	3

Remote Signalling with Insulation Voltage up to 2200 V AC/DC

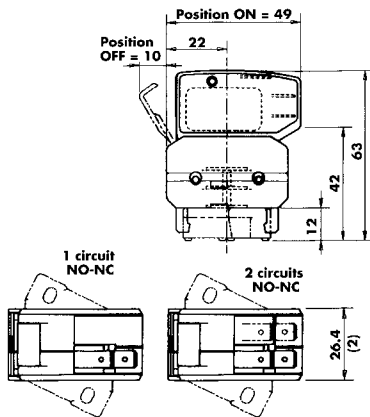

Quantity of NO-NC separated circuits	Contact	Catalog Number	Ref. Number	Weight (g)	Pack. (1)
1	standard	MCR3E 1-5N	G310023	51.7	1
1	low level	MCR3E 1-5NBS	P310030	51.7	1
2	low level	MCR3E 1-9NBS	H310024	58.0	1
1	watertight	MCR3E 1-5NET	Q310031	52.5	1

Remote Signalling with Insulation Voltage up to 6000 V AC/DC

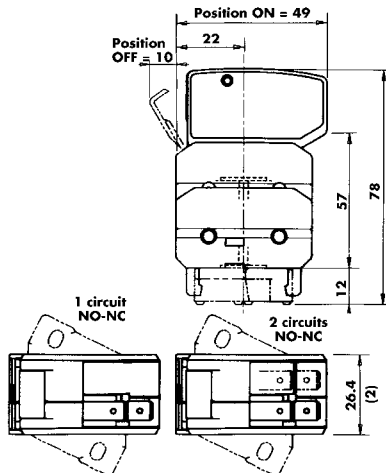

Quantity of NO-NC separated circuits	Contact	Catalog Number	Ref. Number	Weight (g)	Pack. (1)
1	low level	MC2R3E 1-5NBS	J310025	64.0	1
1	watertight	MC2R3E 1-5NET	N310029	64.8	1
2	low level	MC2R3E 1-9NBS	K310026	70.3	1

Electrical diagram of each microswitch circuit

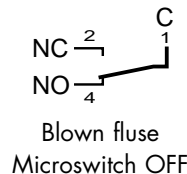
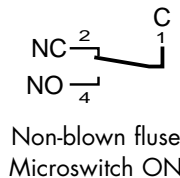

All of these signalling systems are had resettable and fitted with silver-plated 3-terminal microswitch C, NO and NC. The C terminal is on the top and connection is made via 6.35 mm clips except for watertight models whose clips are 4.8 mm wide

NOTE (2): The 26.4 dimension is the same with 1 or 2 separated circuits NO-NC.
 Tests with sine vibrations carried out at ambient with scanning of the three main holder axes.
 Spectrum: 1st segment (2 to 16 Hz) constant trip X = 5 mm peak
 2nd segment (16 to 250 Hz) constant acceleration γ + 5 g peak

Exponential scanning speed: 1 octave per minute.
 Duration: 2 hours per axis.